

## PRECESSION ELEPHANT 2, MULTI-AXIS SCAN HEAD

# SCAN HEAD FOR HIGH-PRECISION DRILLING AND CUTTING

Novanta develops photonics solutions through our globally recognized brands— ARGES, Cambridge Technology, Laser Quantum and Synrad— specializing in cutting-edge components and sub-systems for laser-based diagnostic, analytical, micromachining and fine material processing applications. Powerful lasers, coupled with advanced beam steering and intelligent sub-systems incorporating software and controls, deliver extreme precision and performance, tailored to our customers' demanding applications.

### PRECESSION SCANNING

The PRECESSION ELEPHANT 2 is the perfect solution for precession applications. The heads are designed for high-precision laser drilling, cutting and micromachining applications and are used 24/7 in production facilities around the world.

The PRECESSION ELEPHANT 2 scan head offers maximum flexibility for the drilling of innovative borehole and edge geometries of differing conicity, taper angles and shapes, and allow the production of perfectly round, elliptical and custom-shaped micro holes. The PRECESSION ELEPHANT 2 is available for ultraviolet, green and two infrared wavelength ranges, each with two different focal lengths.

This scan head can be used with all major ultra-short pulsed laser sources available on the market today. In addition, the new PRECESSION ELEPHANT 2 makes it possible to monitor the laser process and the laser beam properties during production. The new scan head offers improved particle extraction, beam attenuation control and additional functionalities designed for mass production of the highest quality. Several other options, such as tools for the setting and calibration of the polarization, simplify the set-up of the scan head and minimize downtimes for the end-user.

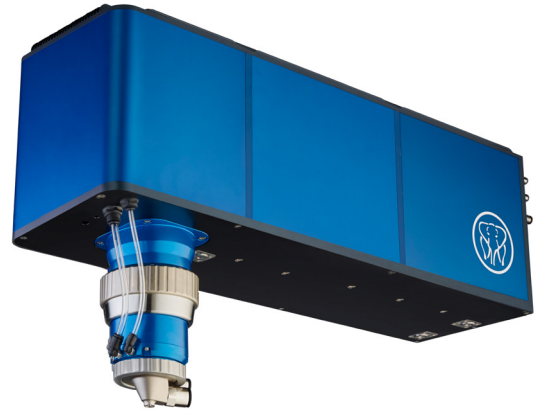

*The PRECESSION ELEPHANT 2 is ideal for micromachining applications.*

### TAILORED ENGINEERING CAPABILITIES

Through our highly specialized expertise and resources we can provide tailored solutions for your application needs. With a large selection of different laser sources, scan heads and handling systems to choose from, we can develop laser processes that are perfectly tailored to a wide variety of customer-specific products, components and materials.

- Laser-specific customization
- Subsystems that include laser and beam path
- Customer-specific software extensions
- Laser process development
- Sample production



*Microprocessing of cobalt-based carbide  
200  $\mu\text{m}$*

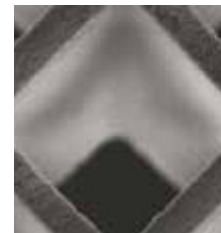

*Bore hole arrays in silicon nitride  
10  $\mu\text{m}$*



*Cutting of coronary stents 100  $\mu\text{m}$*

## PRECESSION ELEPHANT 2, MULTI-AXIS SCAN HEAD

Specifications	PRECESSION ELEPHANT 2
Number of Axes	5 to 8 axes
	X Y Z coordinates
	Two beam inclination angles
	Two polarization parameters
	Beam attenuation value
Wavelength	515 – 532 nm (green)
	1020 – 1080 nm (near infrared)
	1500 – 2100 nm (infrared)
Focal Length of Objective Lens	60 mm or 120 mm
Aperture	26 mm
Precession Frequency	200 – 600 Hz (12 000 – 36 000 rpm), depending on incidence angle
Cooling	Water
Purge Gas (Head / Lens)	Nitrogen / Any

### PROCESS CONTROL OPTIONS

- Customized suction cups for integrated particle extraction with external pressure control
- Through-the-lens vision module with internal sample illumination
- Polarization control for sharpest edges over complete circumference
- High-speed laser stop for consistent edge results on exit surface
- Energy monitor for long-time process stability
- Optical beam attenuator
- Confocal detector
- Plasma emission sensor
- Single pulse energy measurement sensor
- Beam position and profile monitor
- Customized suction cups for integrated particle extraction

### INTEGRATION OPTIONS

- Available as scan head
- Available as scan head, adjusted to your laser source
- Available as scan head with matched laser and beam path
- Stationary or moveable mounting

### SET-UP OPTIONS

- Two alignment cameras for beam adjustment
- Automatic beam position calibration
- Safety shutter

# PRECESSION ELEPHANT 2, MULTI-AXIS SCAN HEAD

## DIMENSIONS (MM)

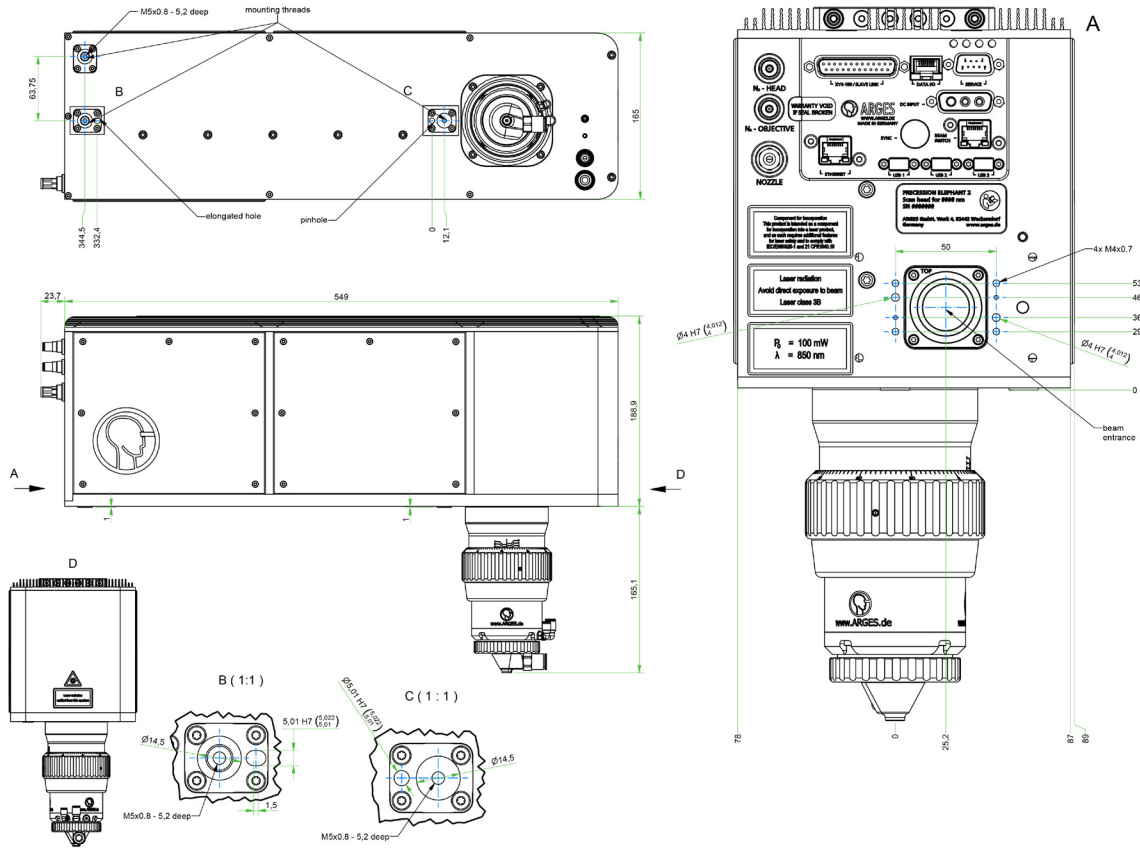

### Notes:

All angles are in optical degrees, unless otherwise noted. Dimensions are in millimeters. All specifications are subject to change without notice.

## CONTACT US

### Americas, Asia Pacific

Novanta Headquarters  
Bedford, USA  
P +1-781-266-5700

Photonics@Novanta.com

### Europe, Middle East, Africa

Novanta Europe GmbH  
Wackersdorf, Germany  
P +49 9431 7984-0

Milan, Italy  
P +39-039-793-710

Photonics@Novanta.com

### China

Novanta Sales & Service Office  
Shenzhen, China  
P +86-755-8280-5395

Suzhou, China  
P +86-512-6283-7080

Photonics.China@Novanta.com

### Japan

Novanta Service & Sales Office  
Tokyo, Japan  
P +81-3-5753-2460

Photonics.Japan@Novanta.com