

p SERIES 100 - 400 WATT AVERAGE OUTPUT POWER PULSED CO<sub>2</sub> LASERS

# INDUSTRIAL PULSED LASERS FOR PRECISION MARKING, DRILLING, AND CUTTING APPLICATIONS

High performance pulsed CO<sub>2</sub> laser engineered for optimal power stability, excellent beam quality, and fastest pulse rise time delivers exceptional quality on the most challenging materials

## CUT AND DRILL FASTER WITH CLEAN, CRISP RESULTS EVEN ON SENSITIVE MATERIALS

The p Series pulse CO<sub>2</sub> lasers cut faster, drill flawlessly and micro-process with precision. Harnessing pulse technology to deliver peak pulse power levels many times greater than standard continuous-wave laser power levels, the p Series expands cutting, drilling and perforating applications to a wider range of materials, including films, high performance textiles, certain metals, and high-tech composites. Internal beam conditioning before the aperture, focuses the beam down to a narrow spot for increased laser processing detail with near-perfect beam quality. Built for industrial environments, all models feature built-in gas purge ports for convenient in-field servicing and protective optical windows.



### Clean Cuts, Faster Throughput

- Excellent stability and high peak power limit the heat affected zone (HAZ), delivering cuts and perforations with minimal discoloration and melt
- Excellent solution for high-speed cutting, drilling and perforating applications on heat sensitive materials
- Zero contact to the target material eliminates surface deformation commonly associated with mechanical cutting systems



## DESIGNED FOR OEMs AND SYSTEM ARCHITECTS

Faster throughput and better results

- 100 - 400 Watts of average power for fast processing speeds
- Fast rise pulse time and excellent power and divergence stability delivers clean, crisp cuts and perforations
- Integrated beam conditioning guarantees a high quality, circular output beam for precise cutting, drilling and intricate feature details

Adds flexibility to OEM machine design

- Unmatched application flexibility with user controlled pulse/continuous wave operation modes
- Real-time performance monitoring (p250 & p400) reduces unplanned downtime with onboard advanced diagnostics that are Industry 4.0 ready

Pulse Model For Heat-Sensitive Materials

- 400 Watts - 1kW of peak power delivers energy more efficiently, minimizing heat affected zone (HAZ) to better process sensitive materials such as thin films, glass, and ceramics

## p SERIES CO<sub>2</sub> LASER SPECIFICATIONS

Performance	Specification			
Model	p100	p150	p250	p400
Wavelength	10.2 Qm, 10.6 Qm	9.3 Qm, 10.2 Qm, 10.6 Qm	10.2 Qm, 10.6 Qm	10.6 Qm
Average Output Power	> 90 W @ 10.2 Qm > 100 W @ 10.6 Qm	> 150 W	> 250 W	> 400 W
Peak Pulse Power <sup>2</sup>	375 W @ 10.2 Qm 400 W @ 10.6 Qm	600 W @ 9.3 & 10.6 Qm 550 W @ 10.2 Qm	750 W @ 10.2 Qm 800 W @ 10.6 Qm	1 kW
Peak Pulse Energy (maximum) <sup>3</sup>	180 mJ @ 10.2 Qm 190 mJ @ 10.6 Qm	335 mJ	600 mJ	1.0 J
Power Stability (cold start) <sup>4</sup>	3.7%	3.5% @ 9.3 Qm 3.6% @ 10.2 and 10.6 Qm	3.5%	3.7%
Power Stability (typical, after 3 min.)	3.5%	3.3%	3.3%	3.5%
Beam Quality (M <sup>2</sup> )	< 1.2			
Beam Diameter <sup>5</sup>	7.5 mm 3.1 mm @ 10.2 Qm 8.0 mm 3.1 mm @ 10.6 Qm	8.5 mm 3.1 mm	8.0 mm 3.1 mm @ 10.2 Qm 9.0 mm 3.1 mm @ 10.6 Qm	1 - 6.5 mm 3.1 mm 2 - 9.0 mm 3.1 mm
Divergence (full angle)	1.8 mrad 3.0 mrad @ 10.2 Qm 2.0 mrad 3.0 mrad @ 10.6 Qm	1.9 mrad 3.0 mrad		1 - 2.5 mrad 3.0 mrad 2 - 1.8 mrad 3.0 mrad
Ellipticity	< 1.2			
Polarization	Linear (Vertical)		Linear (Horizontal)	Linear (45°)
Rise/Fall Time <sup>6</sup>	< 40 Qs / < 80 Qs @ 10.2 Qm < 40 Qs / < 100 Qs @ 10.6 Qm	< 50 Qs / < 100 Qs	< 60 Qs / < 110 Qs	< 50 Qs / < 100 Qs
Operating Frequency	0 - 100 kHz	0 - 130 kHz	0 - 100 kHz	
Duty Cycle Range	≤ 37.5%		≤ 45%	≤ 50%
Maximum Pulse Length	100 Qs	600 Qs	1.0 Qs	
<b>Power Supply</b>				
DC Input Voltage	48 VDC			
Maximum Current	40 A	65 A	90 A	175 A
Pulsed Current	75 A for < 700 Qs	100 A for < 700 Qs	250 A for < 1 Qs	300 A for < 1 Qs
<b>Cooling</b>				
Maximum Heat Load	2000 W	3500 W	4.3 kW	8.5 kW
Coolant Temperature	18 - 22° C (water)			
Minimum Flow Rate (water)	1.5 GPM, < 60 PSI	2.0 GPM, < 60 PSI	3.0 GPM, < 60 PSI	4.0 GPM, < 60 PSI
<b>Environmental</b>				
Operating Ambient Temperature	15 - 40° C			
Maximum Humidity	95%, non-condensing			
<b>Physical</b>				
Length x Width x Height mm (inches)	590x 132 x 155 (23.2 x 5.2 x 6.1)	798x 132 x 155 (31.4 x 5.2 x 6.1)	1252 x 315 x 198 (49.3 x 12.4 x 7.8)	1262 x 208 x 300 (49.7 x 8.2 x 11.8)
Weight kg (lbs.)	13.6 kg (30.0 lbs.)	18.1 kg (40.0 lbs.)	48.5 kg (107 lbs.)	59 kg (130 lbs.)

1 - Power level guaranteed for 2 years from date of shipment, regardless of operation hours, within recommended coolant flow rate and temperature range.

2 - Measured at 1 kHz, 10% duty cycle

3 - Measured from average power at 100 Hz, 10% duty cycle.

4 - Measured as  $3(P_{max} - P_{min}) / (P_{max} + P_{min})$  from cold start at 5 kHz, 50% duty cycle.

5 - Measured 1/e<sup>2</sup> diameter at laser output

6 - Measured at 1 kHz, 10% duty cycle.

Specifications are subject to change without notice.

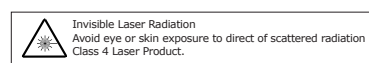

## p SERIES RECOMMENDED APPLICATIONS



When cutting many natural and synthetic textiles cut edge charring or melting is caused by excessive heat build-up in the material. High peak power and fast pulse rise time eliminates this issue, expanding the range of materials for laser processing.

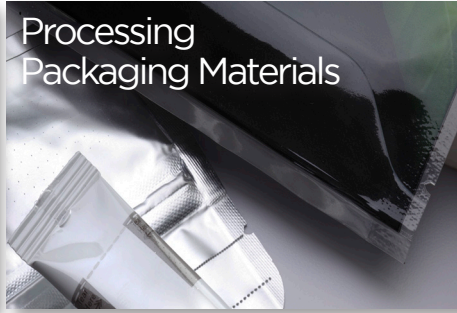

High-speed non-contact drilling and perforating of packaging films and pouches; perfect for easy-open or breathability of perishables.



The high peak power is essential to minimizing heat build-up and avoid cracking when processing brittle materials such as alumina, ceramic and quartz glass. Excellent beam quality allows for very small features and clean symmetric holes.



Continuous output power drives faster throughput for higher production yields. Excellent rise/fall time and divergence stability minimizes HAZ for clean cuts.



Peak power delivers efficient energy, increasing perforating or drilling speeds and reducing HAZ; a solid solution for laser finishing processes on automated packaging lines.



High peak and average power deliver the perfect laser for high quality, precision drilling and cutting applications on a wide variety of thin, sensitive materials.

## p SERIES PERFORMANCE ADVANTAGES



### Superior Edge Cut Quality on a Wide Variety of Materials

Higher average power and peak pulse power delivers high cut quality with faster processing speeds. The unique user switchable pulse/continuous wave modes makes the p Series the most versatile laser source available. Easier field serviceability with a modular electronics package make the p400 and p250 the first choice for high speed industrial processing systems.

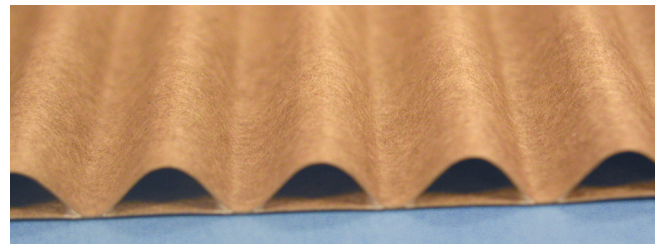

### Clean Cuts, Faster Throughput

Excellent stability and high peak power limits the heat affected zone (HAZ), delivering cuts and perforations with minimal discoloration and melt. With zero contact to the target material, the p Series is an excellent CO2 laser source for sensitive high-speed cutting applications. Zero contact with the target material eliminates surface deformation commonly associated with mechanical cutting systems.

# p SERIES TECHNICAL ILLUSTRATIONS

## p100 - 100 Watts

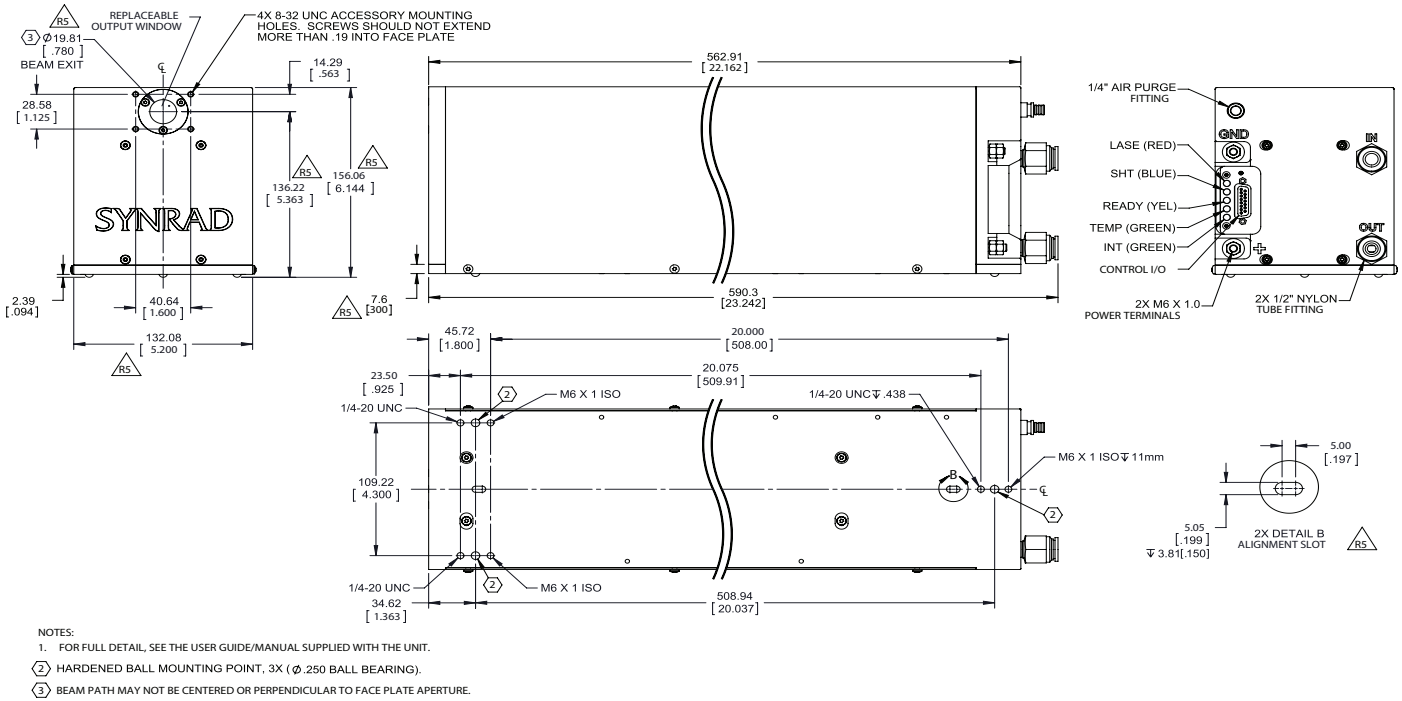

## p150 - 150 Watts

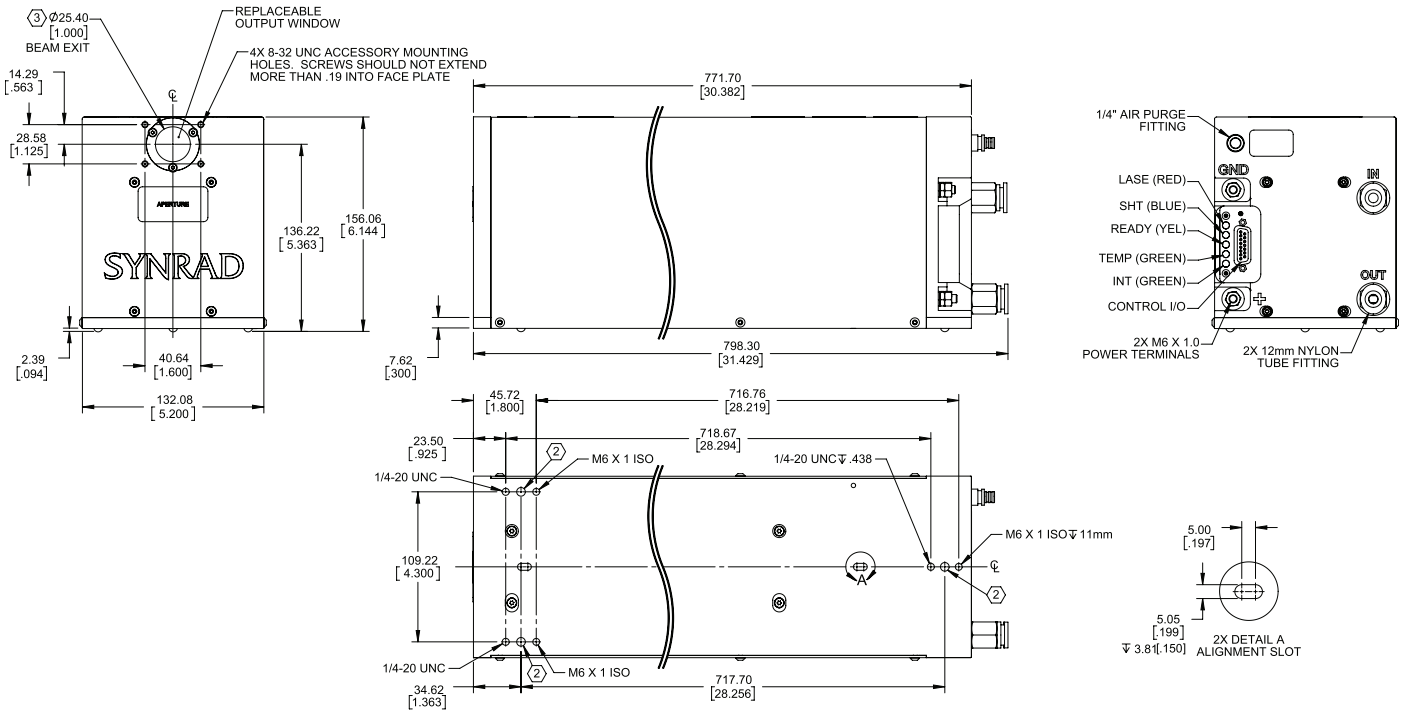

# p SERIES TECHNICAL ILLUSTRATIONS (continued)

## p250 - 250 Watts

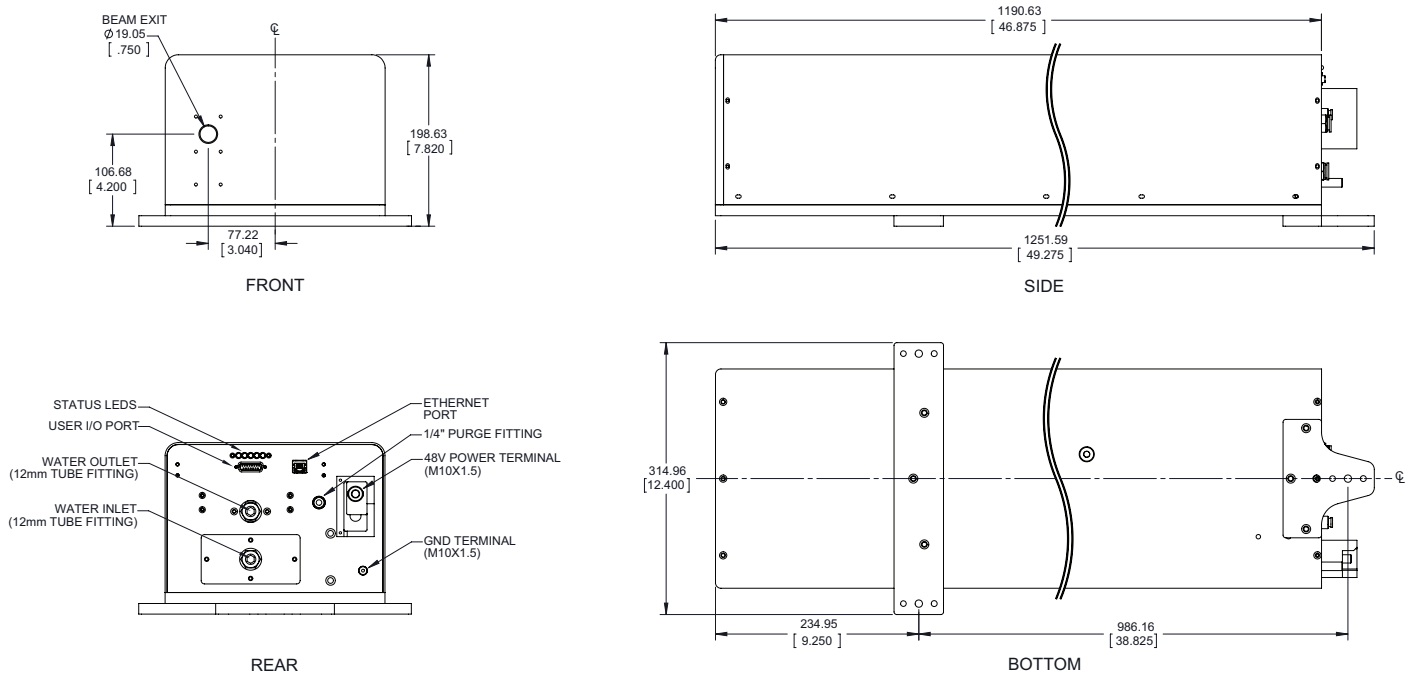

## p400 - 400 Watts

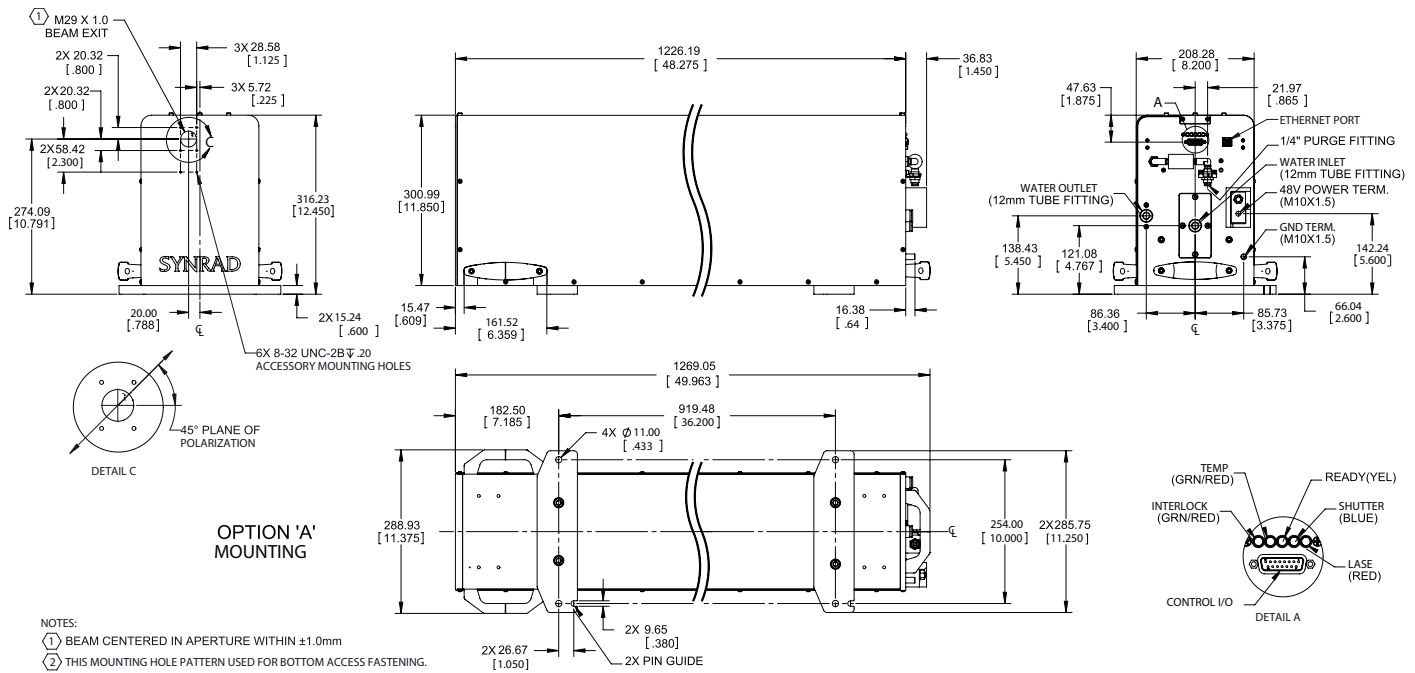

## CONTACT US

Americas & Asia Pacific  
 Novanta Headquarters  
 Bedford, USA  
 P +1-781-266-5700  
 Photonics@Novanta.com

Europe, Middle East, Africa  
 Novanta Europe GmbH  
 Garching, Germany  
 P +49-89-31-707-0  
 Milan, Italy  
 P +39-039-793-710  
 Photonics@Novanta.com

China  
 Novanta Sales & Service Office  
 Shenzhen, China  
 P +86-755-8280-5395  
 Suzhou, China  
 P +86-512-6283-7080  
 Photonics.China@Novanta.com

Japan  
 Novanta Service & Sales Office  
 Tokyo, Japan  
 P +81-3-5753-2460  
 Photonics.Japan@Novanta.com



[www.novanta.com](http://www.novanta.com)